

WELCOME



ARTICULATOR



- ☛ Definition
- ☛ Purpose
- ☛ Uses
- ☛ Requirement
- ☛ Advantages
- ☛ Limitations
- ☛ Classification
- ☛ component
- ☛ Commonly used articulator
- ☛ Selection of an articulator
- ☛ Mounting of cast
- ☛ conclusion

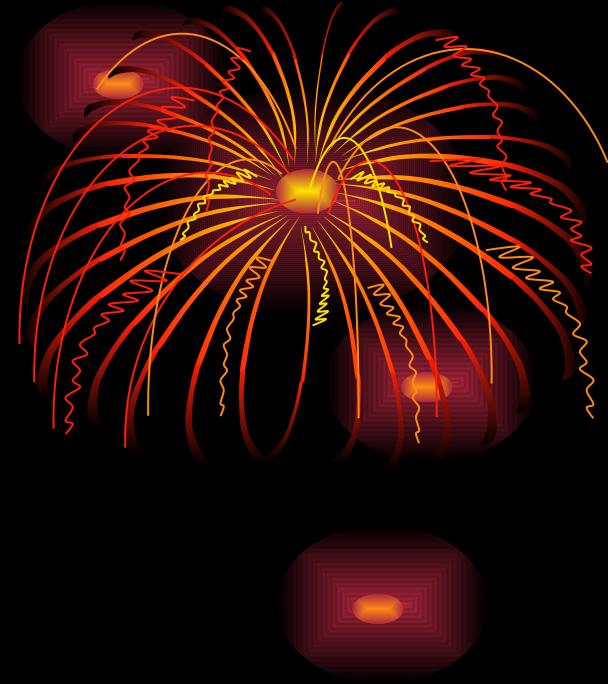

DEFINITION



An articulator may be defined as a mechanical device that represent the temporomandibular joint and jaw members to which maxillary and mandibular casts may be attached to simulate jaw movement.

PURPOSES

1. To hold the maxillary and mandibular casts in a determined fixed relationship
2. Mounting of dental casts for diagnosis treatment planning and patient presentation.
3. To simulate the jaw movement like opening and closing.
4. Fabrication of occlusal surfaces for dental restoration.
5. Arrangement of artificial teeth for complete and removable partial denture.



USES

1. To diagnose the *state of occlusion* in both the natural and artificial dentition.
2. To plan the *dental procedures* based on the relationship between opposing natural and artificial teeth.

Ex. Evaluation of the possibility of *balance occlusion*.



4. To aid in the fabrication of restorations and prosthodontics replacements.



5. To correct and modified restorations.

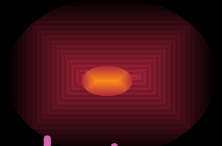

complete

6. To arrange artificial teeth.

REQUIREMENTS

Two Types of Requirements

- a. Minimal requirements
- b. Additional requirements

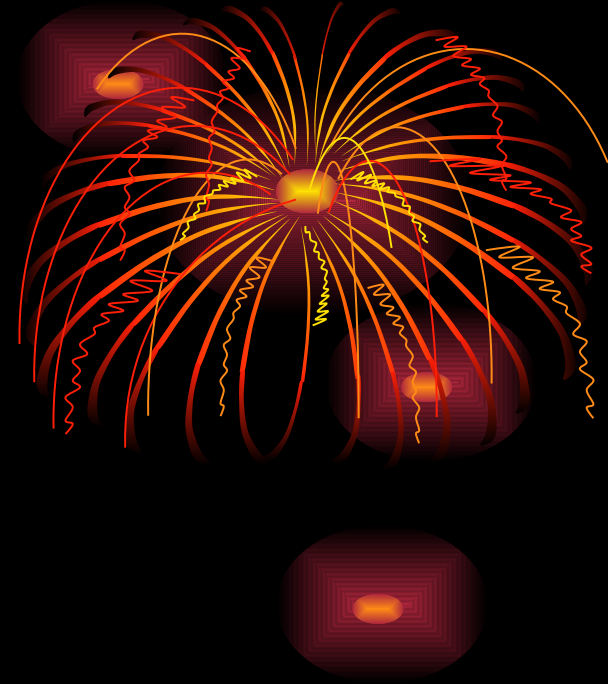

Minimal requirements

They are necessary for the fabrication of *complete denture* to the patients centric position.

They are -

1. It must be accurately *maintain* the correct horizontal and vertical relationship of the patient's casts.



2. The casts should be easily *removable and attachable* to the articulator without losing their correct horizontal and vertical relationship

3. The articulator should have an *incisal guide* pin with a positive stop, that is adjustable and calibrated.

4. The articulator should be able to open and closed in a *hinge like fashion*.



5. The articulator should accept a *face-bow transfer* utilizing an *anterior reference point*.



6. The construction should be *accurate, rigid and of non corrosive material*.

7. The moving parts should move *freely* without any friction.

8. The non moving parts should be of a *rigid construction*.



9. The design should be such that there is *adequate distance* between the upper and lower members.

10. The articulator should be *stable* on the laboratory bench and *not too bulky and heavy*.

ADDITIONAL REQUIREMENT



- The condylar guides should allow *right lateral, left lateral and protrusive movement.*
- The condylar guides should be *adjustable horizontally.*
- The articulator should have provision for adjustment of *Bennett movement.*



- The incisal guide table should be *mechanical table* that can be adjusted in the *sagittal and frontal planes* or a table that can be *customised with autopolymerizing resin or by grinding.*

ADVANTAGES



1. *Properly mounted casts* allow the operator to better visualize the patients occlusion, especially from lingual view.
2. Patient cooperation is not a factor when using an articulator. once *appropriate interocclusal records* are obtained from the patient.
3. A reduces the *chair time, patient appointment time.*



4. The refinement of complete denture occlusion in the mouth is extremely difficult because of *shifting denture bases and resiliency of the supporting tissue.*

Inter occlusal records can be obtained and complete denture occlusion can be refined outside the mouth on an articulator.



5. More procedures can be delegated to auxiliary personnel when utilizing an articulator for *development of patients occlusion.*

6. The patients *saliva, tongue, and cheeks* are not factors when using an articulator.

LIMITATIONS



- ❖ Metal, plastic articulators show errors in tooling, (manufacturer).
- ❖ It not exactly simulate the intraborder and functional movements of the mandible.
- ❖ Errors in jaw relation procedure are reproduced as errors in the denture occlusion. Articulators do not have any provision to indicate or correct these errors.



CLASSIFICATION

OF

ARTICULATORS

CLASSIFICATION OF ARTICULATORS



Several basis of classification of articulator were proposed, some of them are as follows.

- A. Based on the instruments function.
- B. Based on theories of occlusion.
- C. Based on the type of inter occlusal record used.
- D. Based on the adjustabililty of the articulator.

A. BASED ON INSTRUMENT FUNCTION



At the international prosthodontic workshop on complete denture occlusion at the university of Michigan in 1972, the articulators classified based on *instrument capability, intent, recording procedure and record acceptance*

Class I : Hing Type

Class II : Arbitrary - type A

type B

type C

Class III : Average -
type A
type B

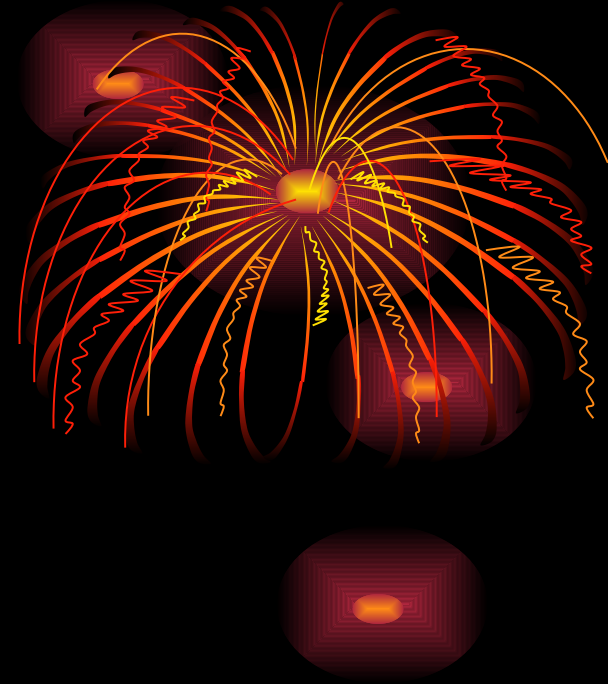

Class Iv : Special -
type A
type B

CLASS I

- ✓ These are *simple articulator* capable of accepting a single registration.
- ✓ *Vertical motion* may or may not be possible.
- ✓ Use in cases where a *tentative jaw relation* is done.

Exp.- Slab articulator

Hinge joint articulator - GARIOT (1805)

Barn door articulator

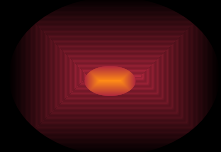

CLASS II

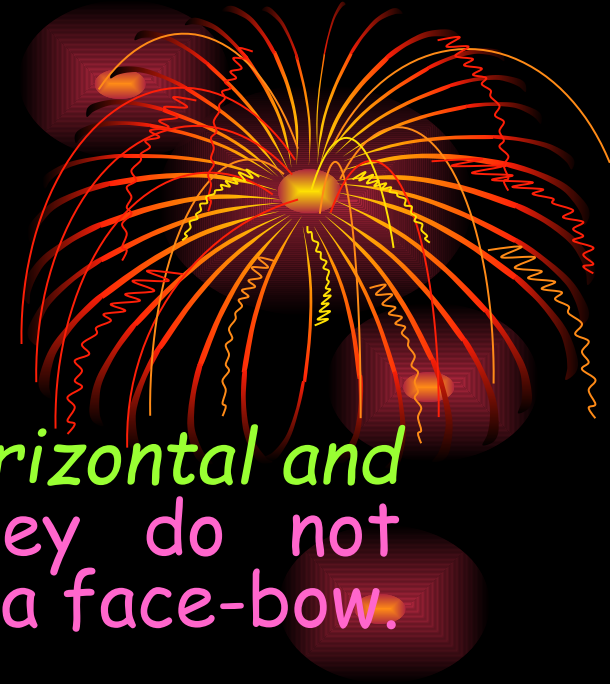

These articulator *permits horizontal and vertical movements* but they do not orient the movement to TMJ a face-bow.

They are -

- TYPE A
- TYPE B
- TYPE C

TYPE A :-

Instruments in this class *permit eccentric motion* based on averages and will not permit face-bow transfer.

The condyles are on the lower member of articulator.

Based on Bonwill's triangle.

Ex. Mean-Value articulator - GYSI



TYPE B :-

Instruments in this class permit *eccentric motion* based on arbitrary theory of motion and will not accept a face-bow transfer.

Based on spheric theory of occlusion.

Ex. Monson's articulator

Hall articulator

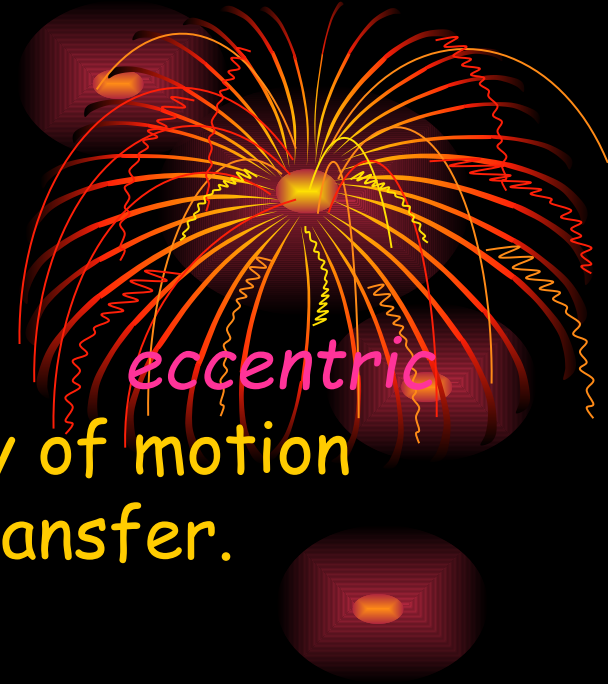

TYPE C :-



Instruments in this class permit *eccentric motion* based on engraved records obtained from the patient and will not accept a face-bow transfer.

Ex.:- House's articulator

CLASS III

- ❖ These articulator permit *horizontal and vertical motion* and they do accept face-bow transfer but these facility is limited.
- ❖ These instruments simulate condylar pathways by using *average or mechanical equivalents* for the whole or part of the condylar motion.

They are -

Type A

Type B

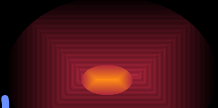
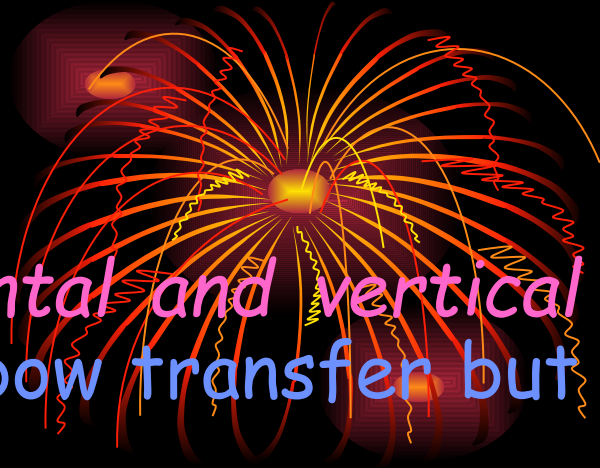

TYPE A :-

- a. They accept a face-bow transfer and a *protrusive interocclusal record.*

Exp. Hanau H articulator- RUDOLPH

HANAU (1923)

Hanau H2 articulator

Bergstrom articulator (ARCON)

TYPE B :-

Instrument in this class accept a face-bow transfer, protrusive interocclusal records, and some lateral interocclusal records.



- Exp. Trubyte articulator - GYSI
- Tripod articulator - STANSBERRY
- Ney articulator - De Pietro (1960)
- Hanau (130-21) - Richard Beu & James Janik (1964)
- Tele Dyne articulator - Richard Beu (1975)
- Pandent articulator - Robert Lee

CLASS IV



- These articulator accept *three dimensional dynamic registration*.
- They are capable of accurately reproducing the *condylar pathway for each patient*.

They are -

Type A

Type B

TYPE A :-



Instruments in this class will accept *three dimensional dynamic registration* and utilise a face-bow transfer.

The condylar pathways are formed by *registration engraved* by the patient.

Exp. TMJ articulator - Kenneth Swanson
(1965)

TYPE B :-

Similar to type a and condylar pathway can be selectively angled and customized.

The procedure utilise the *pantographic tracing*.

- EXP. Pantronic articulator - Dener (1982)
Gnathoscope - Charls Stuart
D 4A & D 5A - Niles Guichet
Simulator - Earnest Granger

BASED ON THEORIES OF ARTICULATOR



A. Bonwill theory articulator - WG A Bonwill.

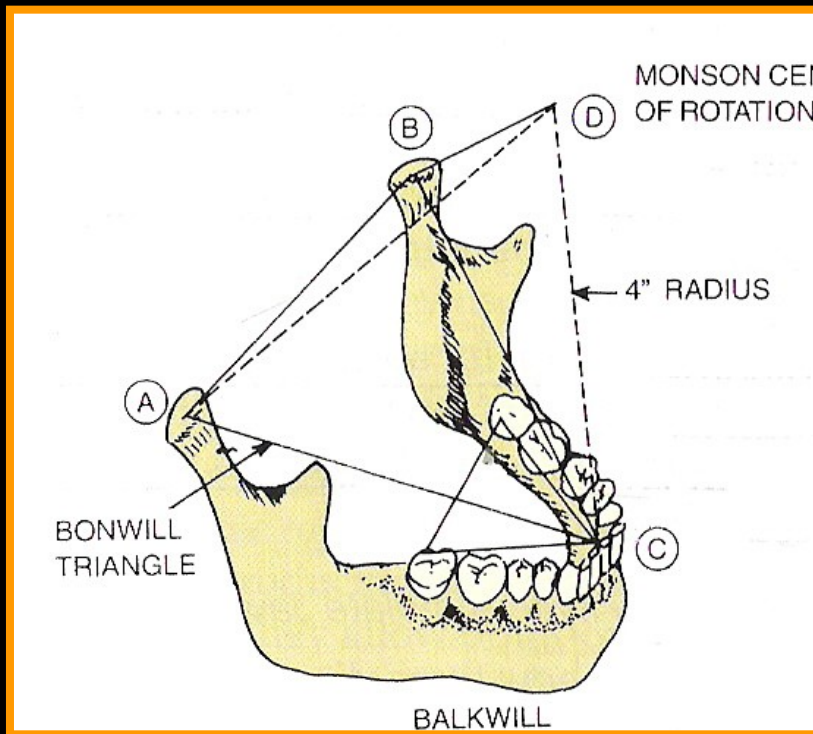

- Known as *theory of equilateral triangle*.
- Allow *lateral movement & permit movement in horizontal plane*.

B. Conical theory articulator - R. E. HALL

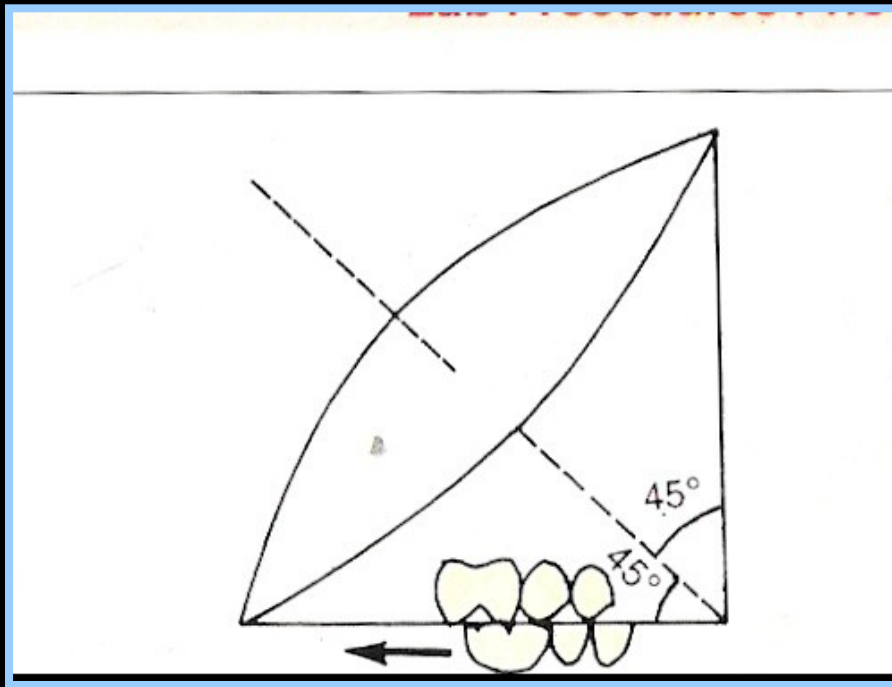

- ✓ Lower teeth move over the surface of the upper teeth as over the surface of a cone generating an angle of 45 degree.

C. Spherical theory articulator-G. S. MONSON



➤ Lower teeth move over the surface of the upper teeth as over a surface of sphere with a diameter of 8 inches.

➤ The center was located in the region of glabella.

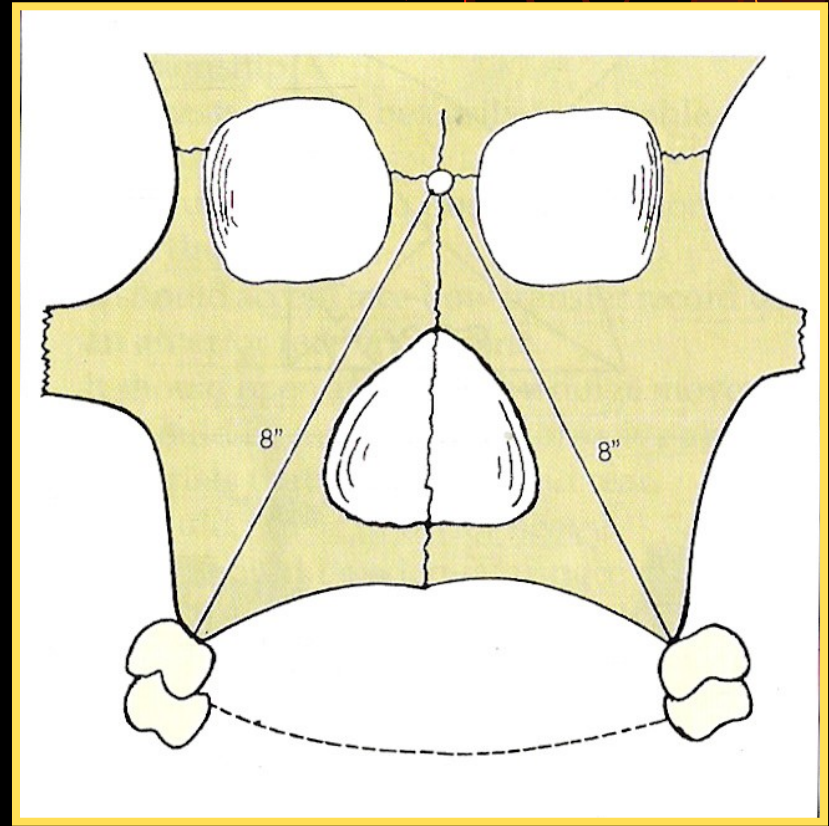

BASED ON THE ADJUSTABILITY

Three Types :-

- a. Non - Adjustable
- b. Semi - Adjustable
- c. Fully - Adjustable

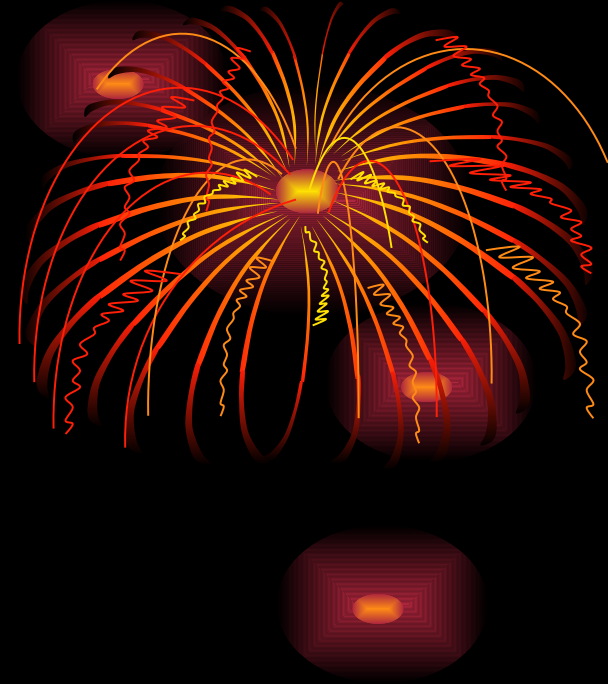

NON - ADJUSTABLE A.



- Can open and close in a *fixed horizontal axis.*
- Have a *fixed condylar path.*
- The incisal pins ride *on an inclined plate in a fixed inclination.*

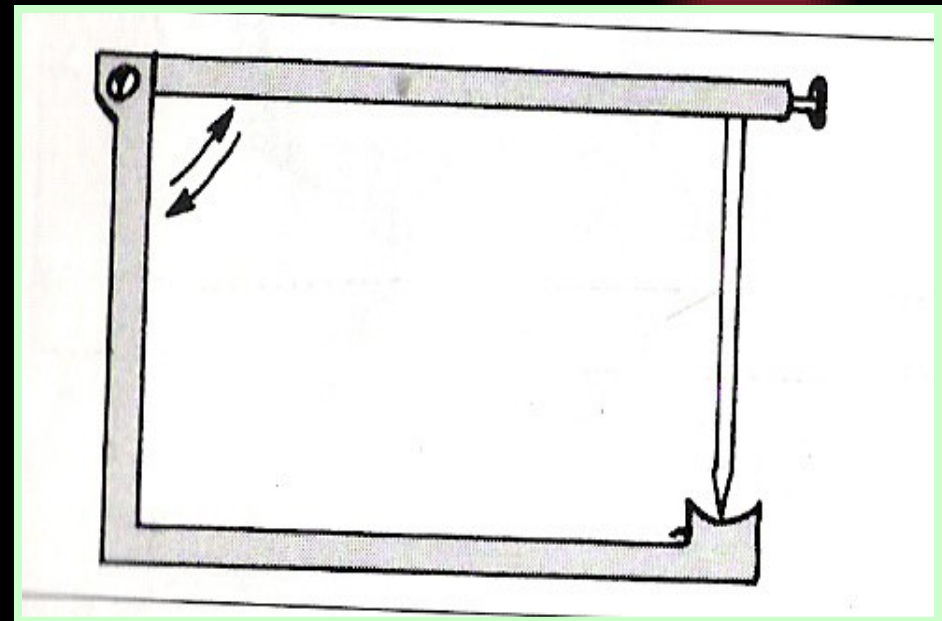

SEMI ADJUSTABLE A.



- Have adjustable horizontal condylar paths, adjustable lateral condylar path adjustable incisal guide table and adjustable inter condylar distance.
- Two Type
 - Arcon Type
 - Non arcon Type

FULLY ADJUSTABLE A.



- ✓ Capable of being adjusted to follow the mandibular movement in all directions.
- ✓ They do not have a condylar guidance; instead, they have receptacles.

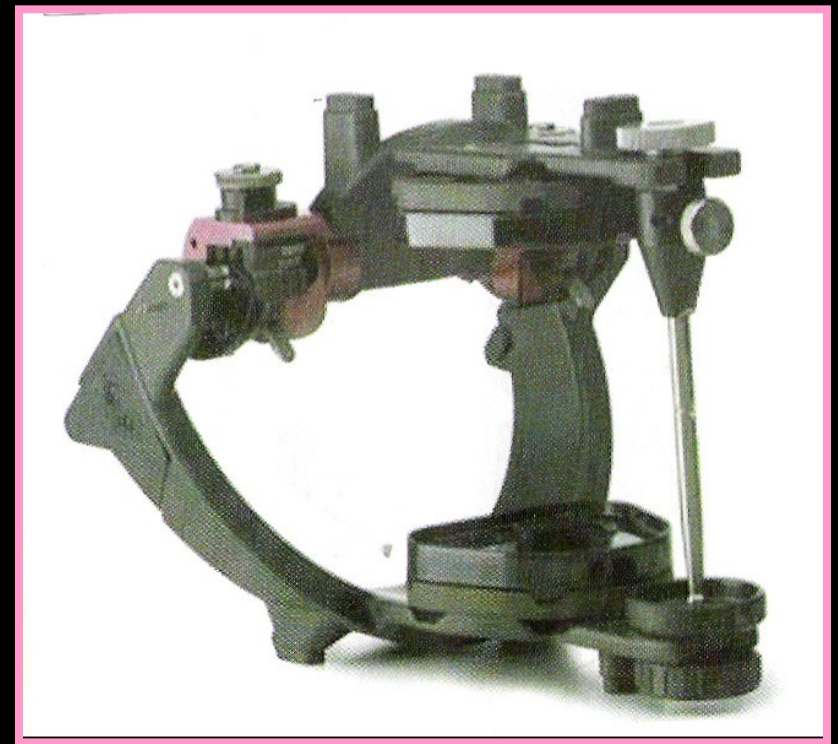

Exp. Stuart Gnathoscope
Simulator

BASIC COMPONENT OF AN ARTICULATOR



- ⊙ Upper member - Represent maxilla
- ⊙ Lower member - Represent mandible
- ⊙ CONDYLAR TRACK -
- ⊙ CONDYLAR ELEMENT-
- ⊙ Vertical Rod (Incisal Pin)
- ⊙ Incisal guide table

SOME COMMONLY USED ARTICULATOR

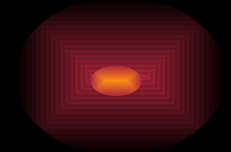

- ☛ Mean-Value Articulator
- ☛ Hanau wide VUE articulator
- ☛ Whip - mix articulator
- ☛ Denar articulator
- ☛ Panadent articulator
- ☛ TMJ articulator

MEAN-VALUE ARTICULATOR

Upper member :-

- Triangular frame
- Vertical Rod with thumb screw.
- Two Condylar elements

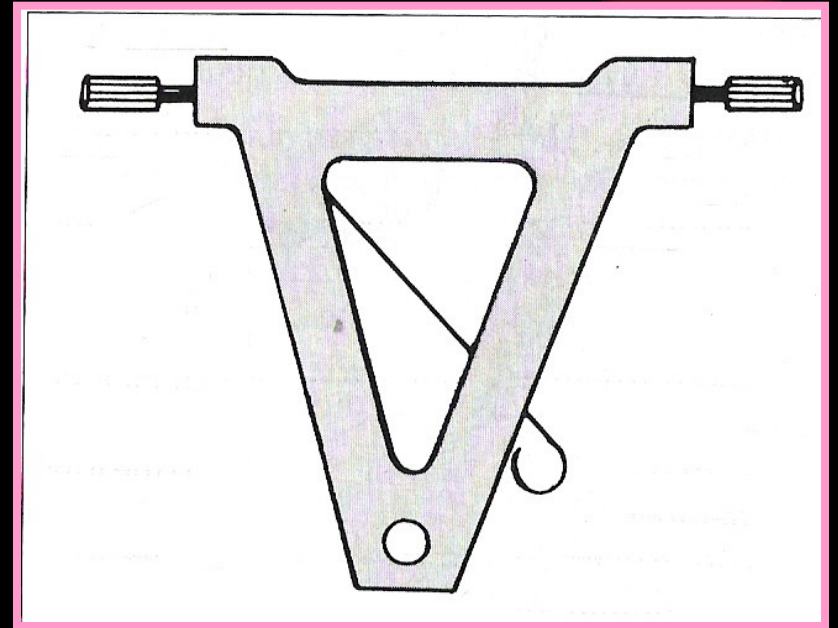

Lower Member :-



- ◆ L Shaped frame with horizontal and vertical arm.
- ◆ Horizontal arm is triangular and its apex contains incisal guide table.
- ◆ Vertical arm is rectangular containing condylar guidance slot at upper portion.

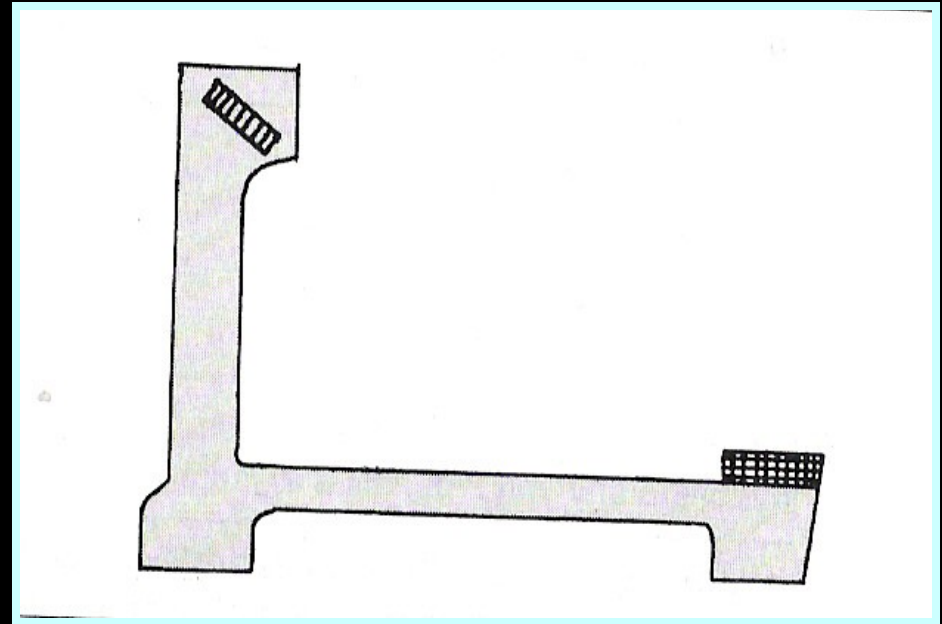

Incisal guide table :-

- ⊗ Contain very short cylinder whose upper surface is concave.
- ⊗ Vertical Rod should rest on the center of the incisal guide table during articulation.

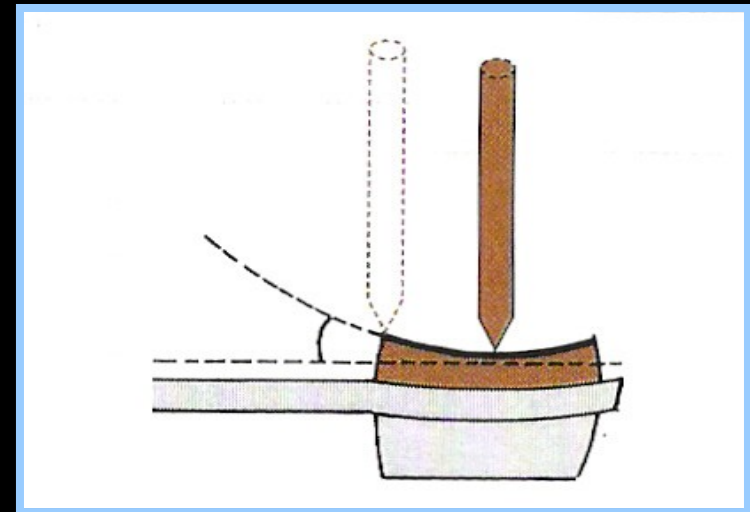
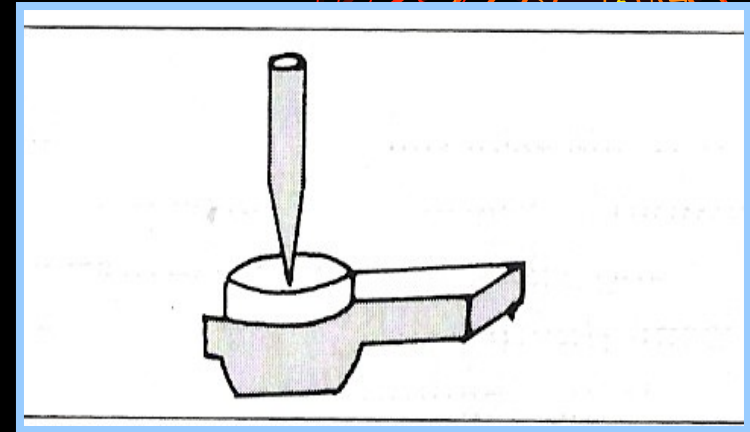

Condylar guidance



- ✓ Represent by a slot
(*condylar track*)
- ✓ Condylar element of upper member passes through this track.
- ✓ *A spring is mounted within this track to established the condylar element.*

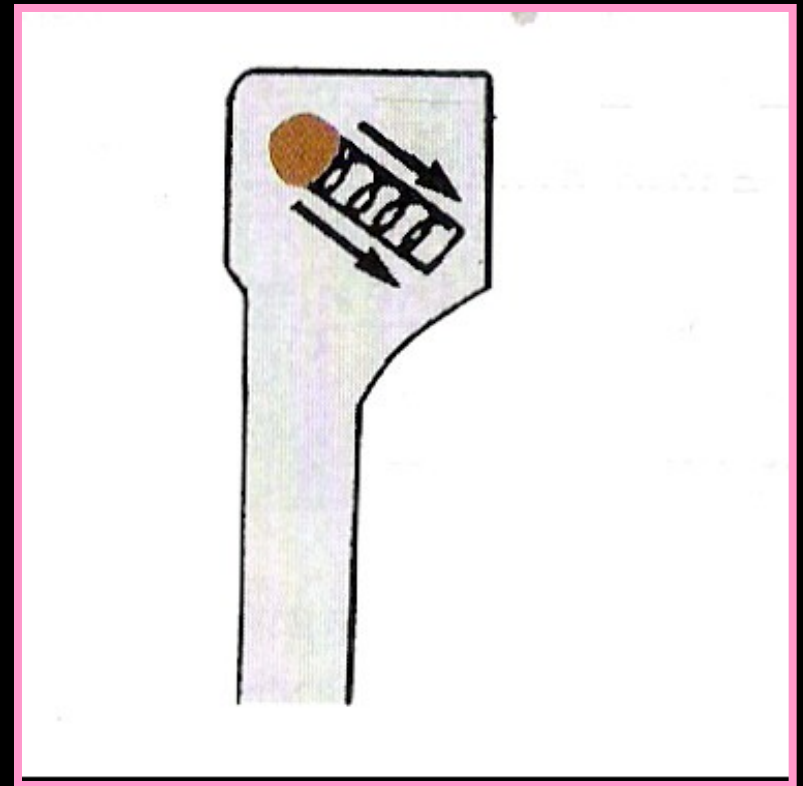

Vertical Rod or Incisal Pin



- ◆ Helps to *keep a fixed distance* between the upper & lower member at anterior end.
- ◆ The pointed tip of vertical rod should rest on the center of incisal guide during articulation.

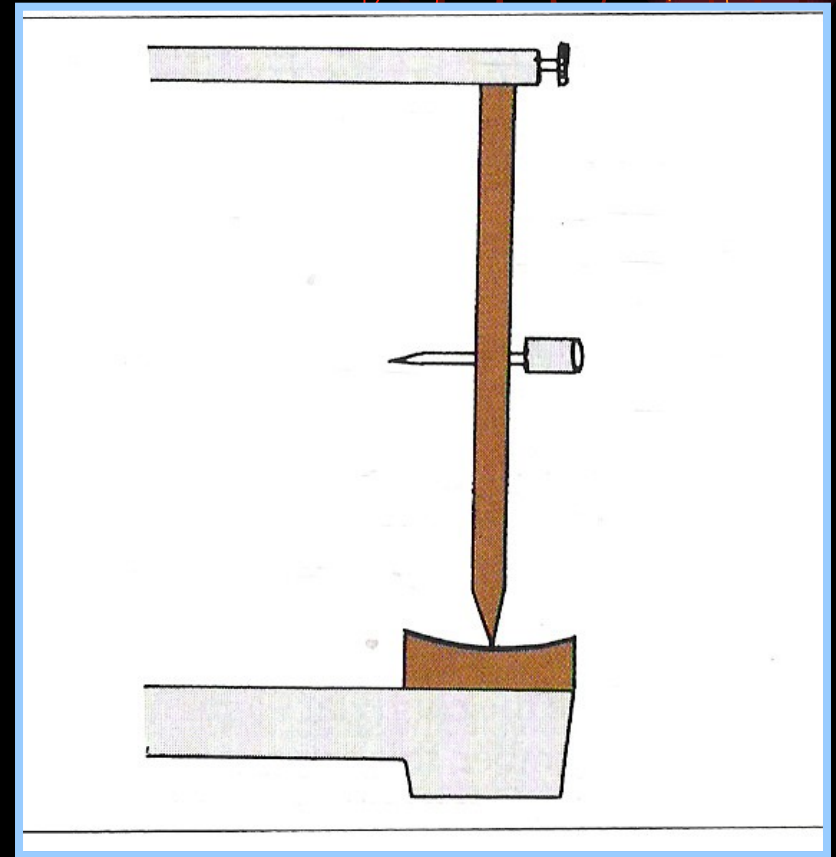

Incisal guide pin :-

Present at the mid point of vertical rod.

The incisal edge of the maxillary incisors *at the mid line of the occlusal rim* should touch the tip of incisal pin during articulation.

It present the anterior reference point.

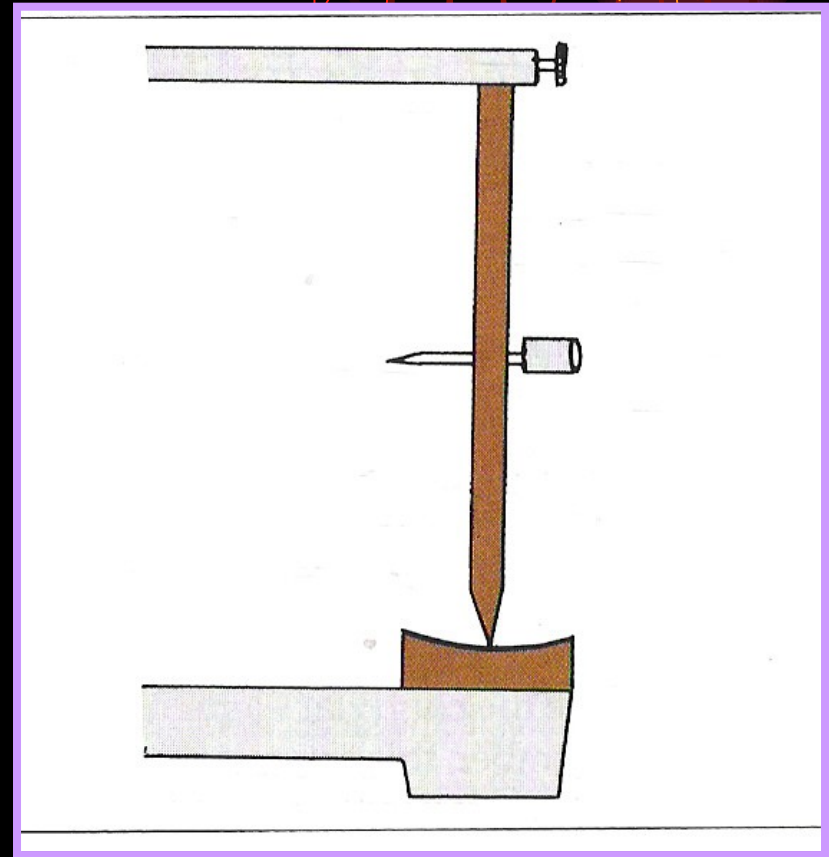

HANAU ARTICULATORS



- ☞ Hanau wide VUE articulator.
- ☞ Hanau wide VUE II articulator
- ☞ Hanau H2 articulator
- ☞ Hanau ARCON articulator
- ☞ Hanau Redialshift

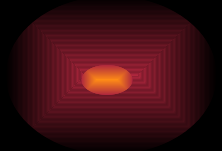

HANUA WIDE VUE A.



- Semi adjustable
- ARCON type
- Accept a Face-bow transfer
- Capable of hinge & lateral movements.

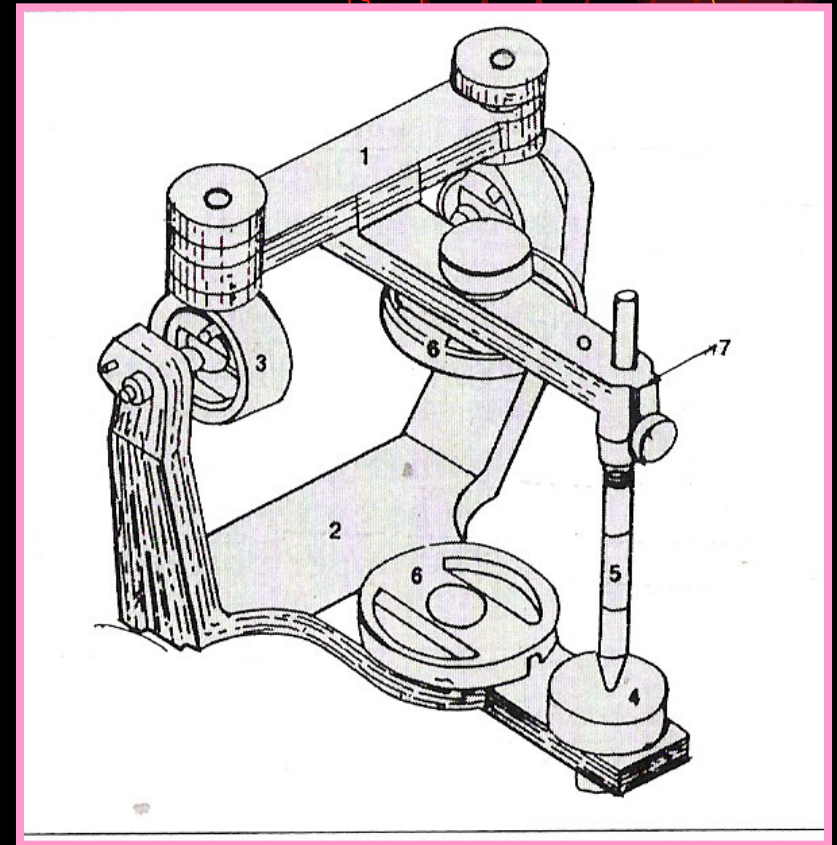

Upper member :-

- ❖ *T.Shaped* with vertical & horizontal arm.
- ❖ *Condylar guidance* attached to this.
- ❖ *Mounting dowels* present the center of under surface.
- ❖ *Orbital indicator* present near dowel.

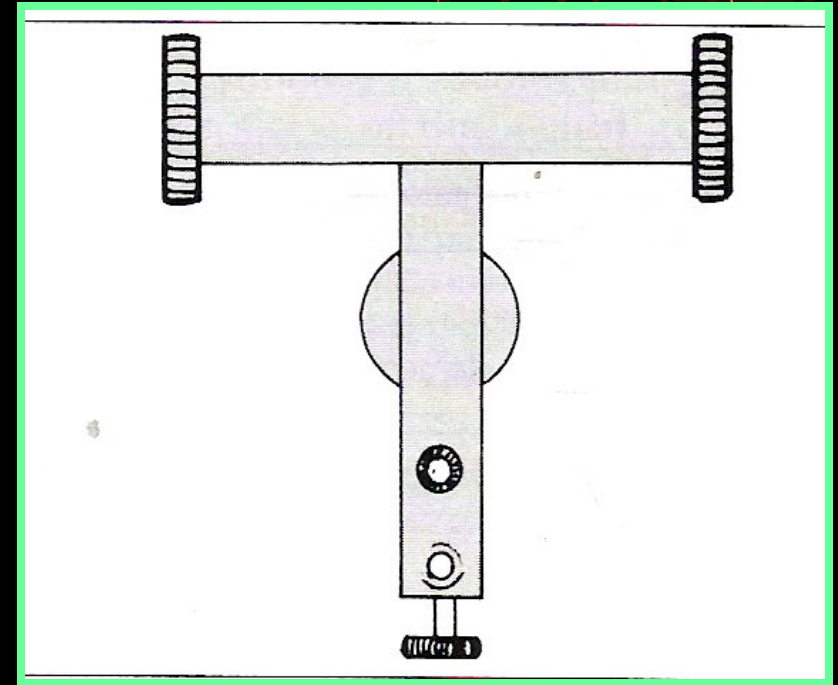

Lower Member :-



- ◆ *L-Shaped* with horizontal & vertical arm.
- ◆ Horizontal arm is *rectangular metal strap*.
- ◆ *Dowel* present center of the lower member for mounting ring & also a stand of pivot.
- ◆ *Vertical arm slope outward*.

- Upper portion of vertical arm contains *a roll pin*. Which project on the outer surface.
- The condylar shaft attached to inner surface of the vertical arm *12-13 mm anterior to the roll pin*.
- The condylar element (*metal ball*) is attached to the free end of the condylar shaft.

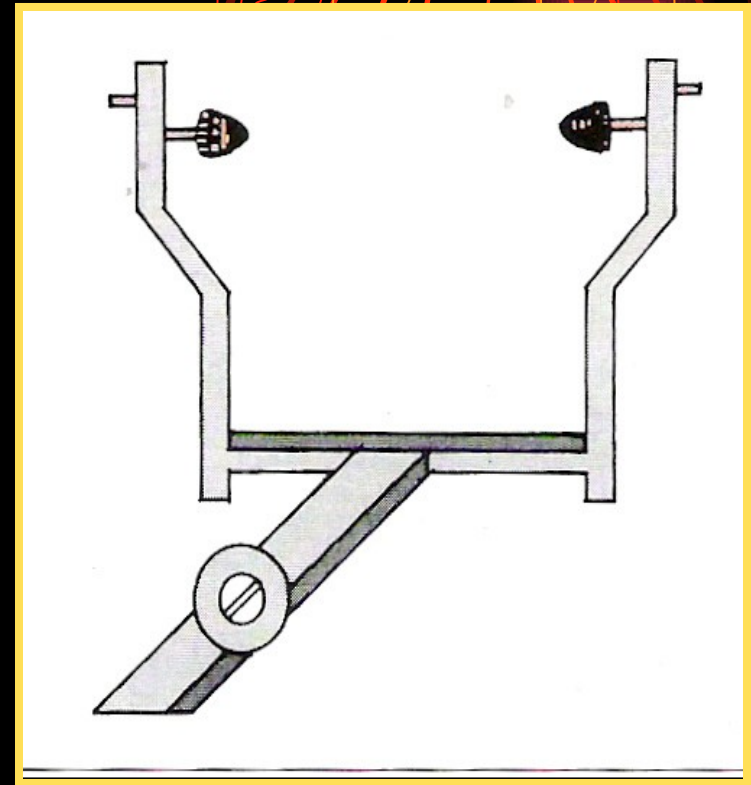
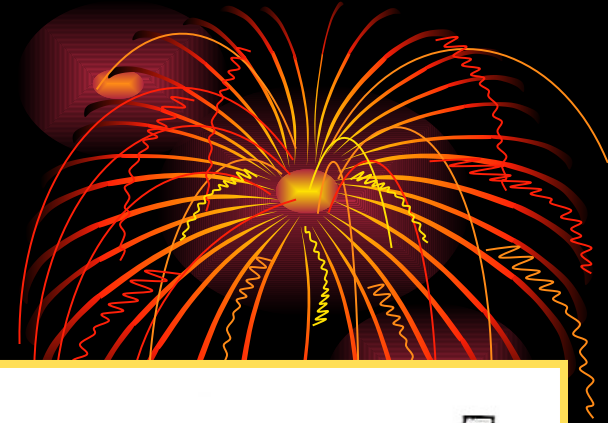

Condylar guidance :-



- It is circular structure with a slot in the center
- The condylar element of lower member articulate with this slot also called condylar track.
- The posterior end of this track has a component known as *centric stop*.

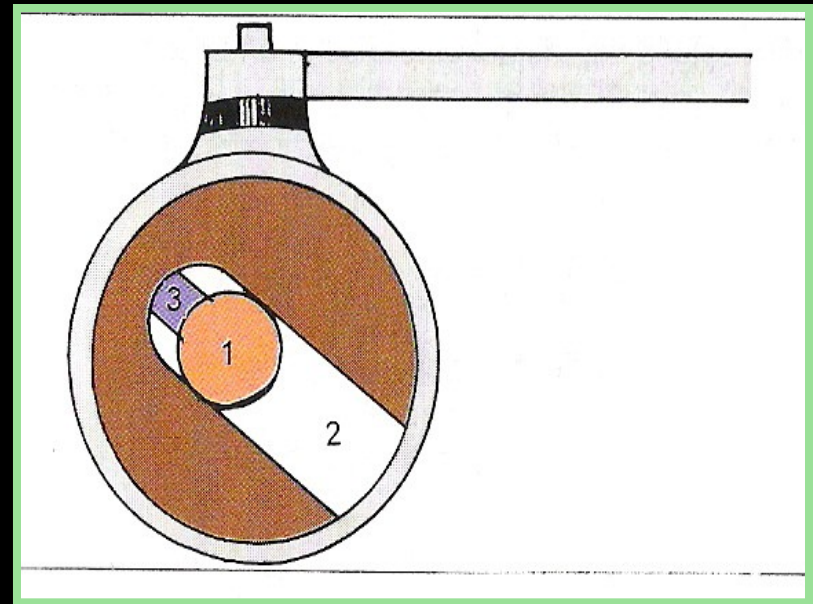

- 
- The condylar element *should contact the centric stop during articulation.*
 - The condylar guidance can be *rotated around the vertical axis to set the Bennett angle.*

$$\text{Bennett angle}(L) = H/8 + 12$$

H = Horizontal condylar inclination

Incisal guide table :-



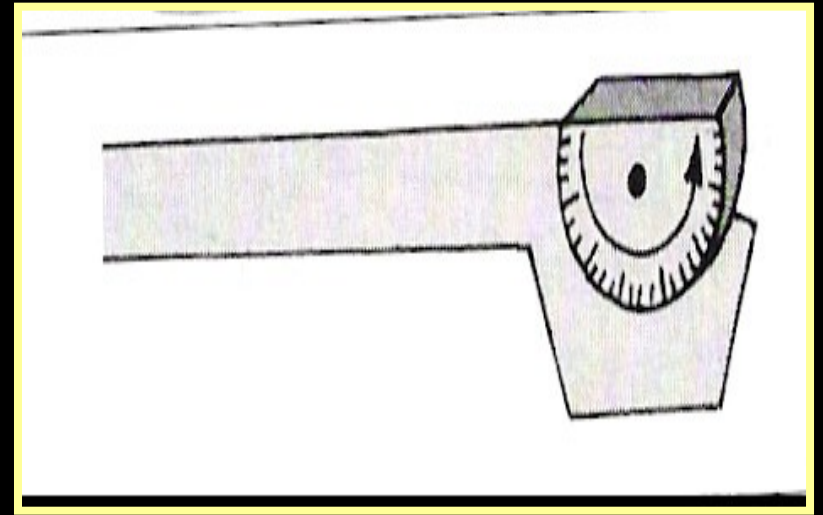

- ❖ It has a customised incisal guide table.
- ❖ The slope of the incisal guide table can be changed in the antero posterior direction & can lock in position with a lock nut.
- ❖ During articulation it should be flat & the incisal pin should be at in center.
- ❖ A pair of lateral wings is present around it.

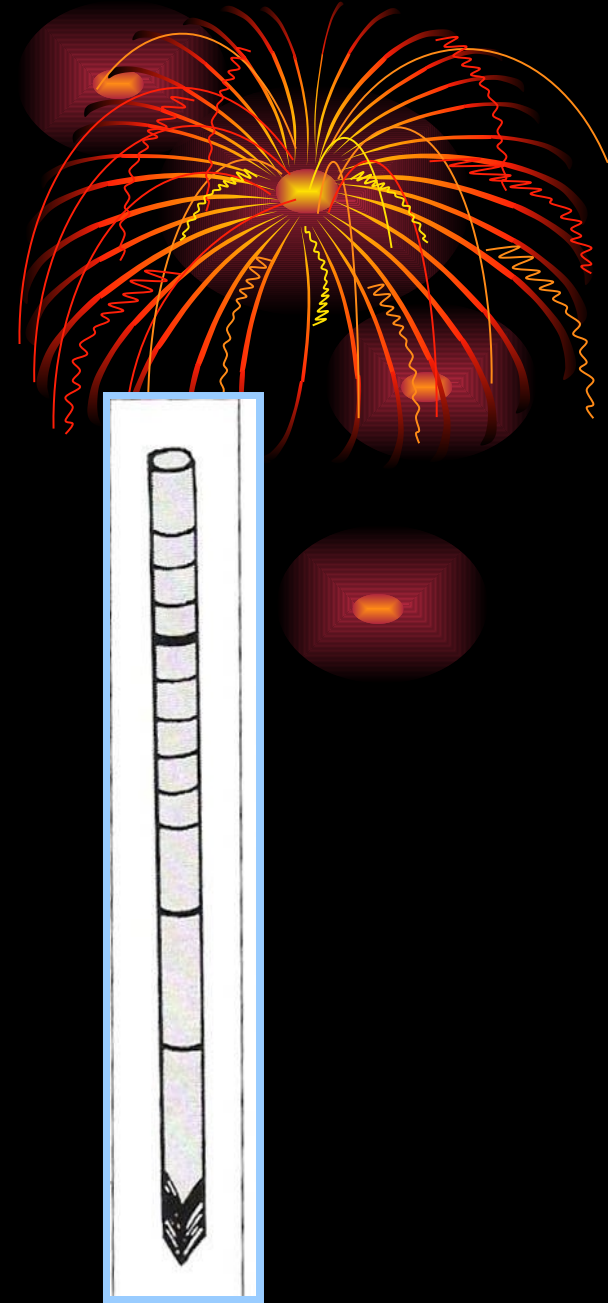

Incisal Pin :-

- It is a double sided pin.
- One end is sharp but chisel like with flat edge. The other end tapers to a pointed tip.
- Usually the flat end is used.
- The incisal pin has *series of markings* closely placed in one end & two widely spaced marking in other end.





⊛ The upper member of the articulator should be at the level of the darkest marking of the close markings.

⊛ The space out markings acts as the anterior reference point in the absence of face-bow transfer.

HANAU H2

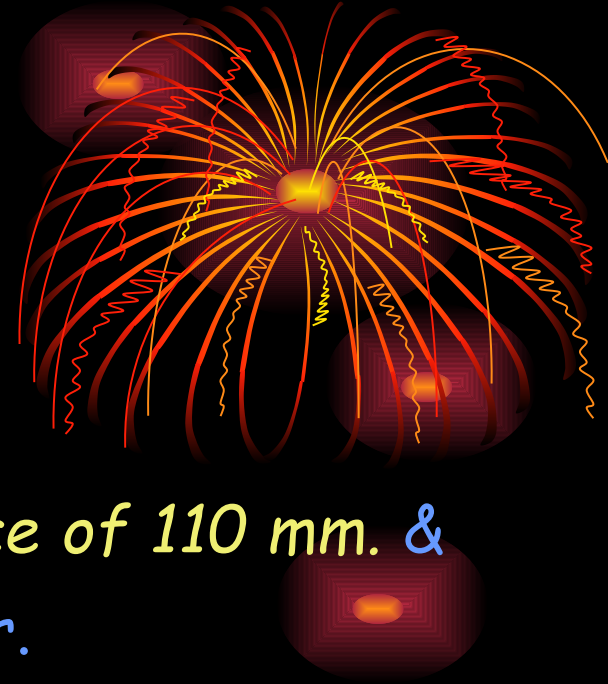

- Designed by *Rudolph Hanau*.
- It is *non arcon type* articulator.
- It has a *fixed intercondylar distance of 110 mm.* & does not accept a face-bow transfer.
- Four different face-bow can be utilised -
 1. *Facia face-bow*
 2. *Earpiece face-bow*
 3. *Twirl face-bow*
 4. *Adjustable axis face-bow*

HANAU RADIAL SHIFT



- ✓ Structure is almost same as *Hanau series articulator*.
- ✓ It has *right & left Centric Latches* & the upper member is easily removed for waxing.
- ✓ The radial shift adjustment has a *3mm radius* and allow upto *3 mm.of radial shift* before intercepting preadjusted prograssive Bennett angle.

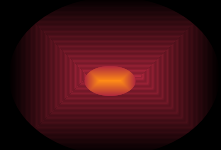

HANAU WIDE VUE II



- The only difference between Hanau wide vue & vue II that the *wide vue has way closed condylar track*.
- The closed condylar track *does not allow the upper member to be removed*, Whereas the open condylar track allow the upper member to be removed for waxing.



WHIP-MIX ARTICULATOR



- ✓ Designed by Dr. Charles Stuart 1963.
- ✓ It is an *arcon articulator*.
- ✓ The upper & lower member are mechanically attached by means of a *spring latch assembly*.





- The original model is 8500.
- The condylar elements on the lower frame & adjustable to *three position*
 1. Small (S) - 96 mm
 2. Medium (M)-110mm
 3. Large (L) - 124 mm.

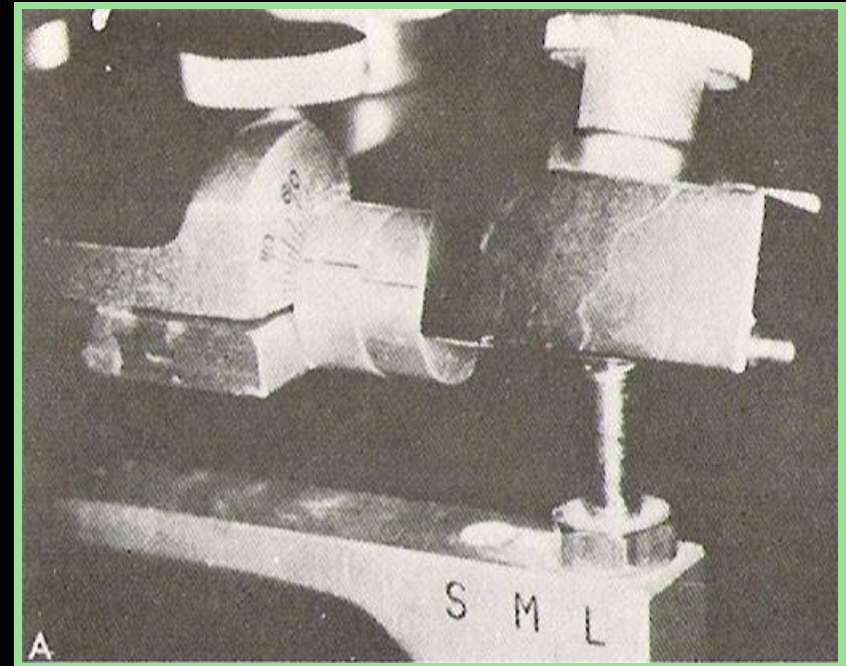

- ✦ Two Different face-bows can be utilised.

- ✦ Quick mount or earpiece face-bow for complete denture.

- ✦ The adjustable axis for fixed prosthodontics.

- ✦ The intercondylar distance is determined from the scale on the face-bow S.M.L.

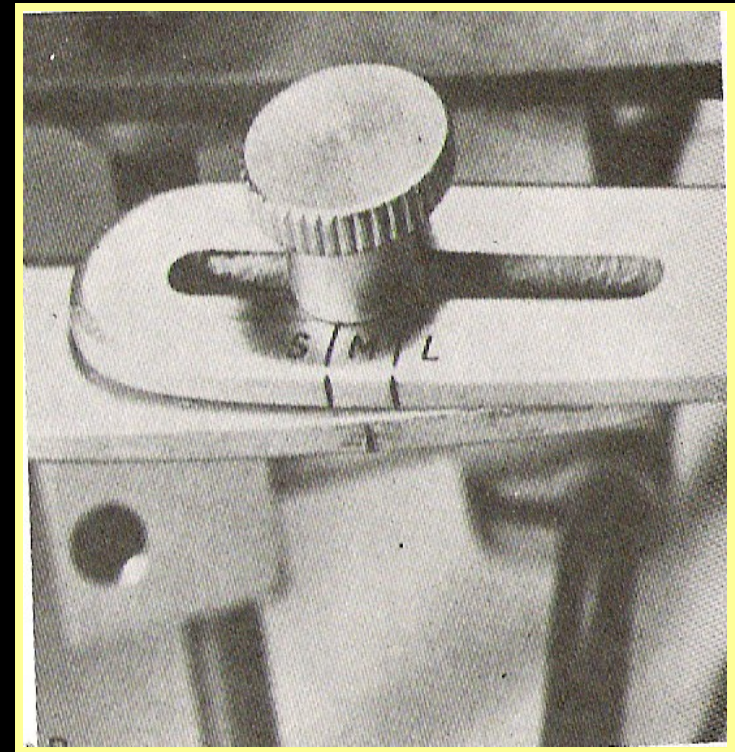



- The articulator has pins on the outer flanges of the condylar guides corresponding holes on the medial side of the earpieces of the face-bow make for easy transfer of the face-bow record to the articulator.

MODIFICATIONS

- ✓ Articulator model 9600 is similar to model 8500 except the lower frame is $\frac{1}{2}$ inches taller to provide more space for mounting the mandibular cast.
- ✓ Mode 8800 provides an additional $\frac{1}{2}$ inches space to mount the maxillary cast.





- Model 9800 is combines the upper frame of model 8800 with the lower frame of model 9000 to provide the greatest distance between the upper & lower frames.
- Model 8340 assure that cast can be interchanged between any model 8340 articulator without loss of accuracy.

DENAR ARTICULATORS

- ❖ DENAR MARK II
- ❖ Arcon type
- ❖ The articulator is a two piece instrument incorporating a positive locking mechanism that can hold the two member together by means of centric latch.





The condylar elements are at a fixed 110 mm intercondylar distance however an adjustable distance (110 to 122) mm option is available.

Four types of face-bow can be used :-

- *Facia face-bow*
- *Earpiece face-bow*
- *Sidematic face-bow*
- *Adjustable axis face-bow*

- 
- The sidematic face-bow has a feature of unique *slide gear machinasm* which make it easy & quick to assemble.

- The mark II can be programmed using *anatomic averages positional records* or with a mini recorder.

OMNI

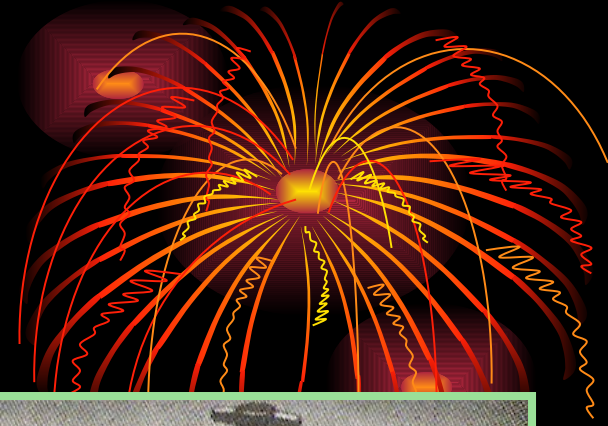

- It is a newest *Denar* articulator.
- The design allow one to easily exchange closed fossa for open fossa with a positive locking latch.

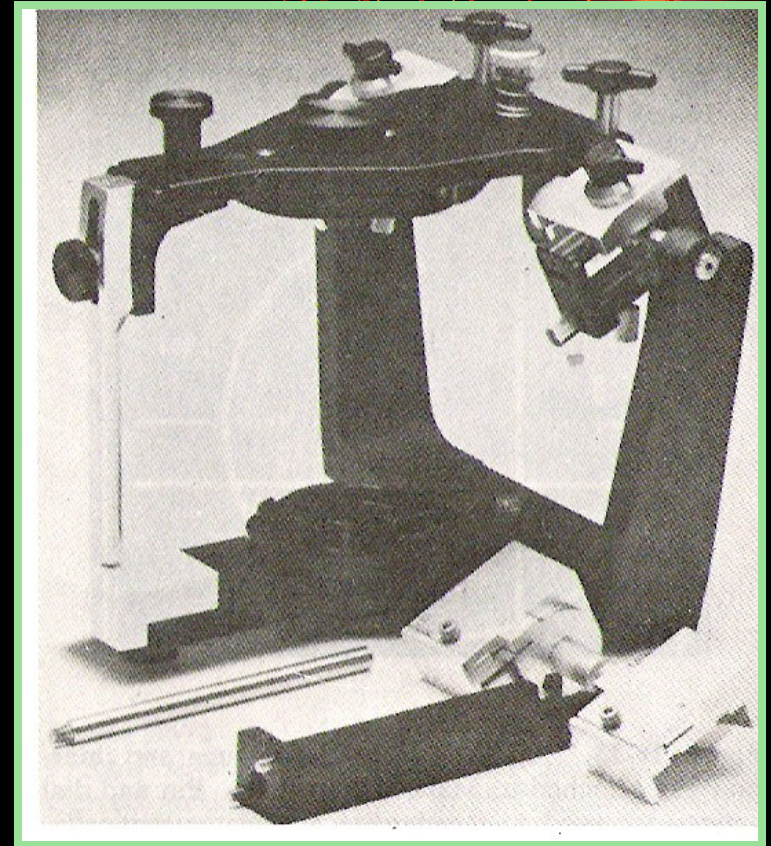



o The purpose of this model is an attempt to better meet the requirements for complete denture, removable & fixed partial denture fabrication in one articulator.





o When the articulator is equipped with the open fossae which is identical to mark II fossa it is called *omni mark*.

o When it is utilised with closed track fossa called *omni track*.

TMJ ARTICULATOR

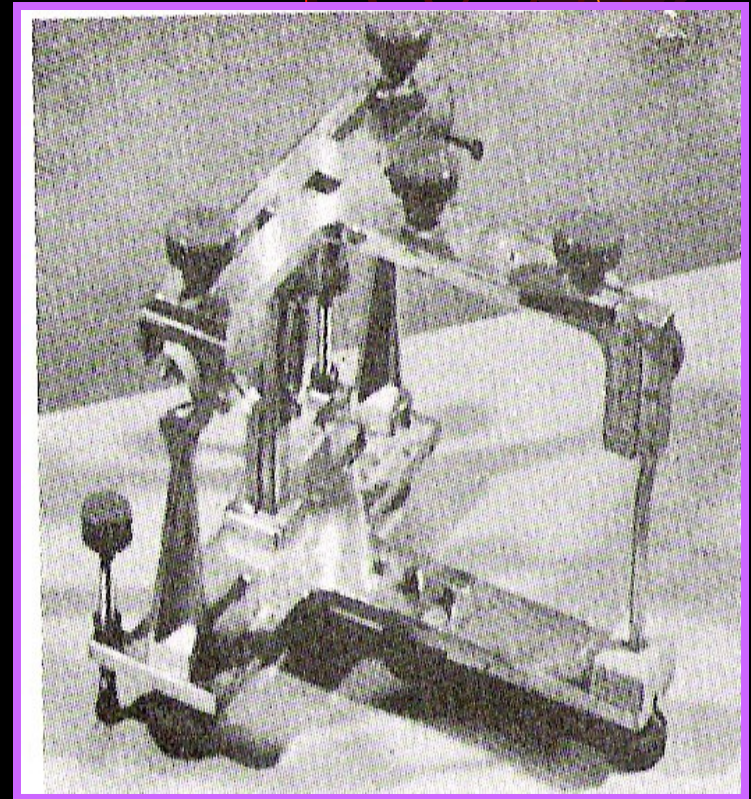
- ◆ Designed by (1965) Kenneth Swanson.
- ◆ The articulator has a spring loaded latch to help return the upper frame to the centric relation position.
- ◆ There is curved incisal guide pin with both a plastic & adjustable mechanical incisal table.





Small version of the articulator is available & is called the *mini articulator*.

Its intercondylar distance is limited & has a *straight incisal guide pin*.

DENTATUS



- ☛ It is a *shaft type instrument*.
- ☛ The condylar element attached to the upper member & the condylar path is straight.
- ☛ The intercondylar distance is fixed.
- ☛ The articulator received a *hinge axis face-bow*.
- ☛ The features are *similar to Hanau model*.

SELECTION

OF AN

ARTICULATOR

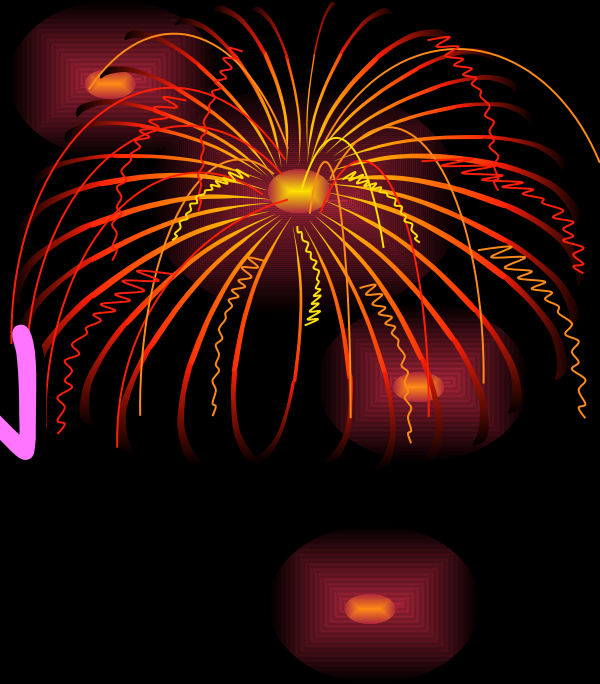

SELECTION OF AN ARTICULATOR



- One should not use too complex instruments for a simple case or too simple articulator for a complex case.
- The following factors are pertinent to the understanding and selection.

- 
1. Articulator movements of the condylar elements *do not reproduced condylar movement* in the temporomandibular joint.
 2. The goals of articulation is to *duplicate tooth movements along border path ways in at least to planes of space.*
 3. The most important requirment of an articulator are to *maintain centric relation & the vertical dimension of occlusion.*



4. Fixed condylar elements at 110mm are all that is necessary. An adjustable intercondylar capability may permit more records to be accepted.

5. The articulator should be able to receive a *face-bow transfer record*,

6. The articulator should have the *capability of adjustment* for precurrent or immediate side shift upto atleast 2.5 mm.

7. An adjustable mechanical incisal guide table can not reproduce the natural guidance of the anterior teeth.



8. A stereograph (pantograph) has limited value for all but a few types of prosthodontics situation.

9. The sophistication of articulators should not exceed the level of training & ability of the personnel that will be fabricating the restorations.

MOUNTING PROCEDURE



Mounting of maxillary cast.

Mounting of mandibular cast.

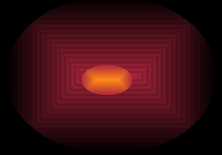

Mounting of maxillary cast



- ❖ Maxillary cast is attached to the articulator using the orientation jaw relation record.
- ❖ Procedure of transferring the orientation jaw relation to the articulator is called **face-bow transfer**.

☛ The ear piece of the face bow is attached to the *rollpin of the articulator.*

☛ This transfers the *posterior reference point of the face-bow to the articulator*

☛ The anterior reference point should be positioned *by making the orbital indicator contact the orbital pointer of the face-bow.*

☛ A pivot stand attached to the lower member of the articulator also helps to *prevent vertical displacement of the occlusal rim during articulation.*

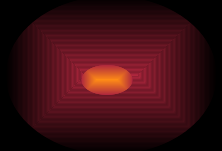

Mounting of mandibular cast



- ◆ *Tighten the centric lock* on each enclosed condylar track mechanism to ensure that the articulator is capable of nothing but a *hinge opening*.
- ◆ *Invert the articulator on the benchtop* resting it on the *three thumbnuts* protruding from the upper member of the articulator.

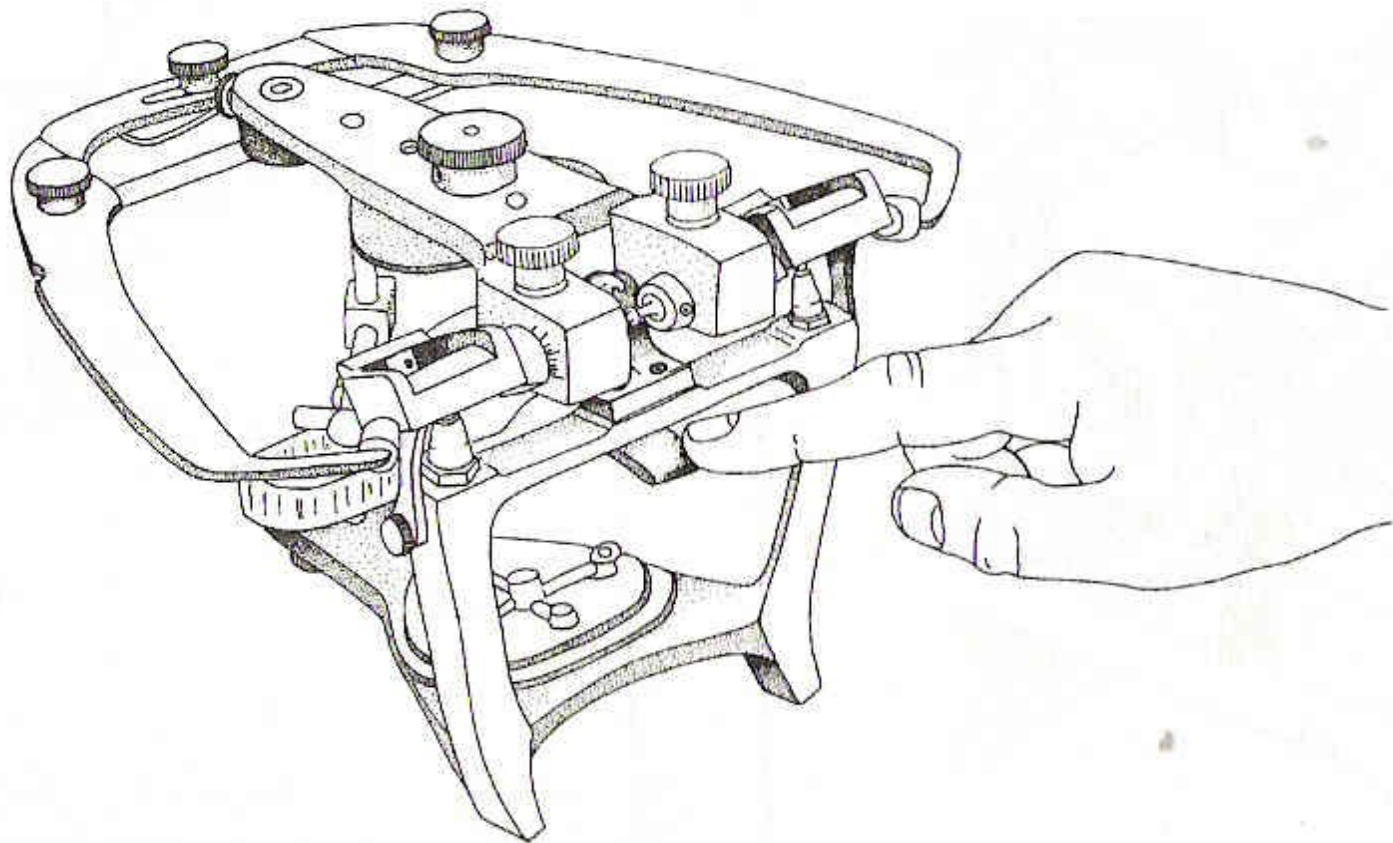

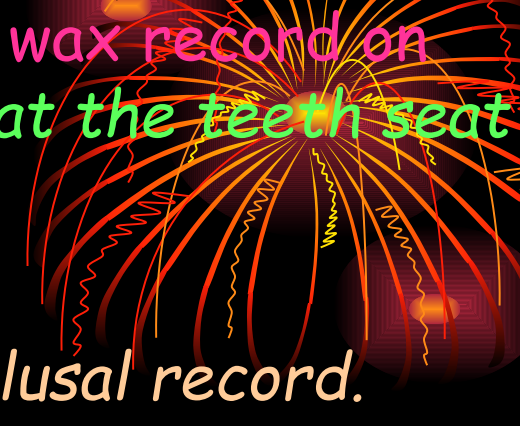
- 
- ◆ Place the centric relation interocclusal wax record on the teeth of maxillary cast. *Be sure that the teeth seat completely into wax record.*
 - ◆ Place the mandibular cast into *interocclusal record.*
 - ◆ There should be *no contact between the maxillary and mandibular cast.*
 - ◆ Remove the mandibular cast and soak it *for about 2 minute in slurry water.*
 - ◆ Reseat the soaked mandibular cast *into the record and mount it by plaster/stone.*

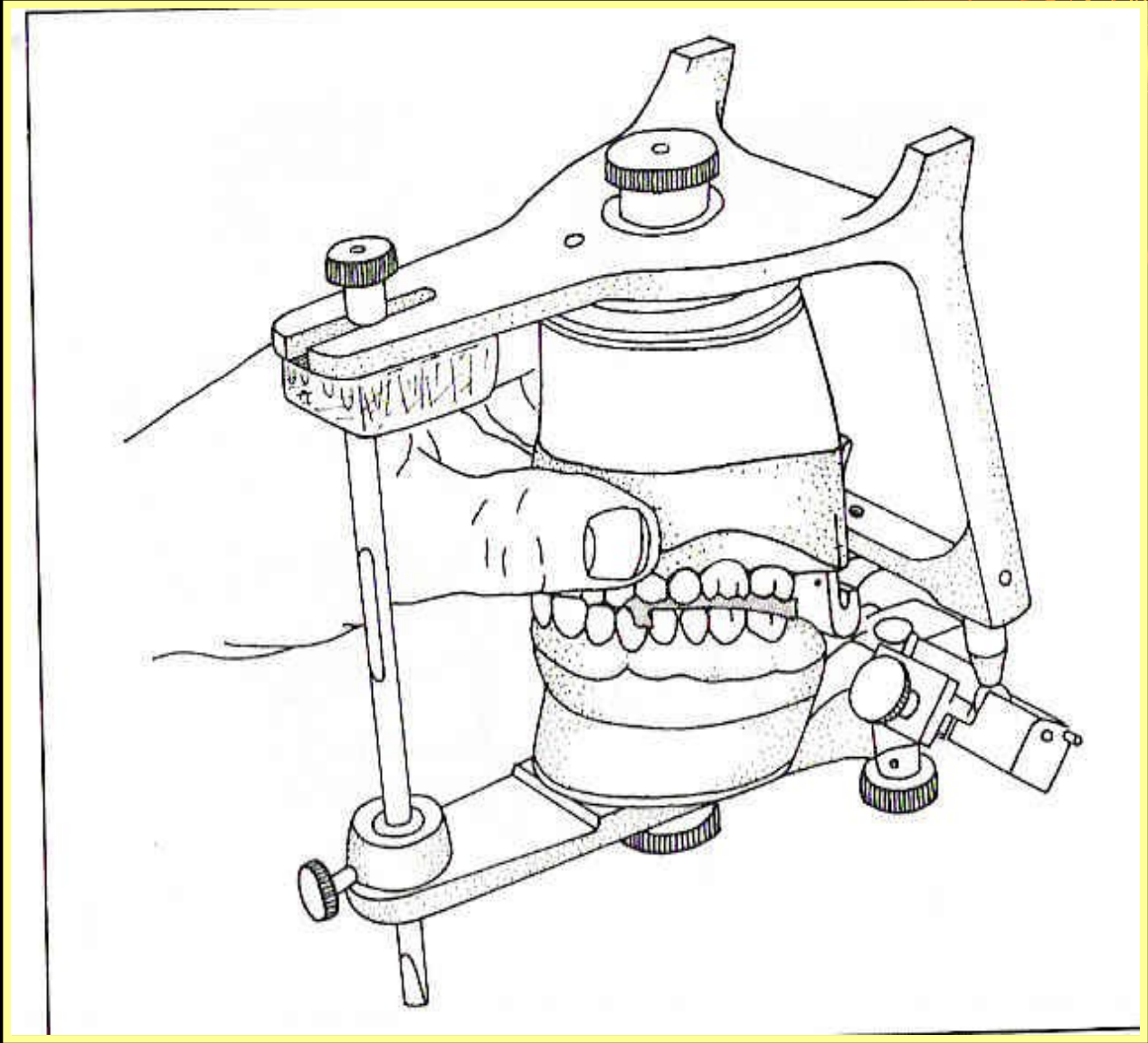

Inspect the articulated cast:-



- ❖ The condyle is in the retruded position in its condylar track mechanism.
- ❖ Both casts are seated completely in the interocclusal wax record.
- ❖ Mounting stone is securely attached to both casts and mounting plates.

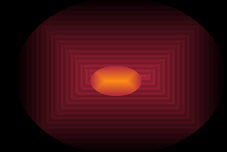

CONCLUSION



An articulator is an important device that mechanically analogues the temporomandibular joint & upper and lower dental arches.

A device to which maxillary and mandibular casts can be attached, with the intent of simulating the functional & para functional contact relationships of one arch to the other.

REFERENCES



- Charles M. Heartwell- the syllabus of complete denture, fourth edition.
- Sheldon Winkler- the essential of complete denture prosthodontics, second edition.
- Herbert T. Shillingburg- fundamentals of fixed prosthodontics, third edition.
- Deepak Nallaswamy- the text book of Prosthodontics, first edition.

THANK YOU

